

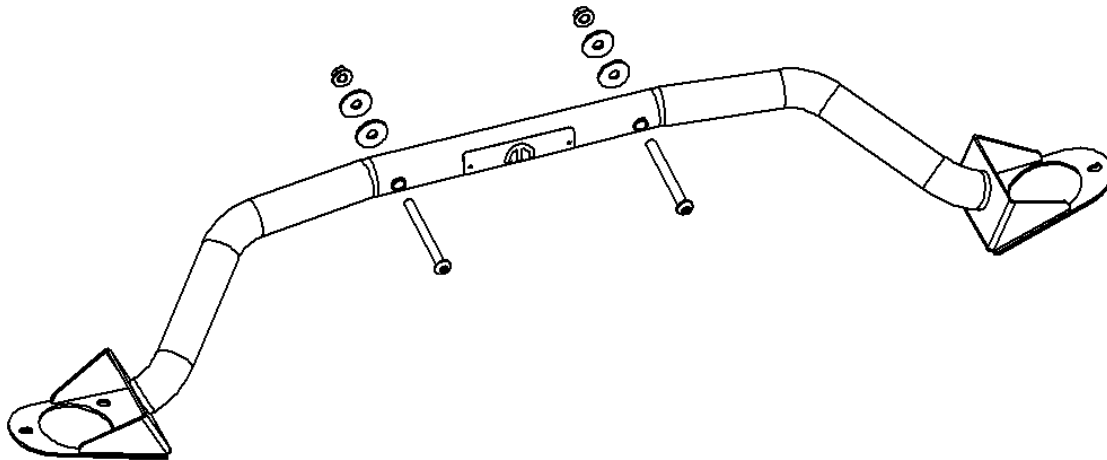

INSTALLATION INSTRUCTIONS
2008-2011 CHALLENGER (5.7L / 6.1L/6.4L)
2006-2011 CHARGER (5.7L / 6.1L)
2005-2011 300C (5.7L / 6.1L)
2005-2008 MAGNUM (5.7L / 6.1L)
STRUT BAR KIT
PART NUMBER P5155950

Strut Bar Kit Bill of Materials

A	1	Instruction Sheet
B	1	LC-LD-LX Front Strut Bar
C	2	3/8"-16x4" Bolt
D	2	3/8"-16 Ny-Lock Nut
E	4	Washer



READ ALL INSTRUCTIONS BEFORE BEGINNING INSTALLATION

WARNINGS AND CAUTIONS:

MOPAR PERFORMANCE PARTS RECOMMENDS PROFESSIONAL INSTALLATION. A VEHICLE HOIST, TORQUE WRENCHES AND SPECIALIZED REMOVAL AND INSTALLATION TOOLS MAY BE REQUIRED.



INSTALLATION INSTRUCTIONS
2008-2011 CHALLENGER (5.7L / 6.1L/6.4L)
2006-2011 CHARGER (5.7L / 6.1L)
2005-2011 300C (5.7L / 6.1L)
2005-2008 MAGNUM (5.7L / 6.1L)
STRUT BAR KIT
PART NUMBER P5155950

STRUT BAR KIT INSTALLATION

Utilize a flat work area (preferably concrete).

Under The Hood:

1. Where applicable remove engine cover (5.7L) and strut tower covers (fig A)
2. Remove the six (3 per side) 8mm nuts from the top of the strut tower. (FIG B & C)
3. Place the strut bar over the studs and tighten the six (3 per side) 8mm nuts to 40Nm (30ft-lbs) (FIG D). It may be necessary to lift up the front of the car (using a lift or floor jack) until the strut studs drop down to create enough room to install the strut bar

2008+ models, to gain maximum performance from your strut bar it is recommended that you bolt the strut bar to the chassis brace. If you do not want to drill the chassis brace go to step 9. For models with 6.4L engine, it would be helpful to use an angle drill.

4. Using the bushings in the strut bar as a guide, drill two 13/32 holes in the chassis brace (FIG E).
5. Remove strut bar and debur holes in chassis brace
6. Place the strut bar over the studs and finger tighten the six (3 per side) 8mm nuts (FIG D)
7. Insert one (1) 3/8" bolt in strut brace; locate one (1) washer between strut bar and chassis brace, secure finger tight with one (1) washer and one (1) 3/8" nut (FIG F&G)
8. Repeat step 6 for 2nd chassis brace fixing.
9. Tighten 8mm stud nuts to 40Nm (30ft-lbs): tighten 3/8" bolts to 13Nm (10ft-lbs)



INSTALLATION INSTRUCTIONS
2008-2011 CHALLENGER (5.7L / 6.1L/6.4L)
2006-2011 CHARGER (5.7L / 6.1L)
2005-2011 300C (5.7L / 6.1L)
2005-2008 MAGNUM (5.7L / 6.1L)
STRUT BAR KIT
PART NUMBER P5155950

10. RE-CHECK ALL YOUR WORK. Where applicable replace engine cover (5.7L)



FIG A



FIG B



FIG C



INSTALLATION INSTRUCTIONS
2008-2011 CHALLENGER (5.7L / 6.1L/6.4L)
2006-2011 CHARGER (5.7L / 6.1L)
2005-2011 300C (5.7L / 6.1L)
2005-2008 MAGNUM (5.7L / 6.1L)
STRUT BAR KIT
PART NUMBER P5155950



FIG D



FIG E



FIG F



INSTALLATION INSTRUCTIONS
2008-2011 CHALLENGER (5.7L / 6.1L/6.4L)
2006-2011 CHARGER (5.7L / 6.1L)
2005-2011 300C (5.7L / 6.1L)
2005-2008 MAGNUM (5.7L / 6.1L)
STRUT BAR KIT
PART NUMBER P5155950

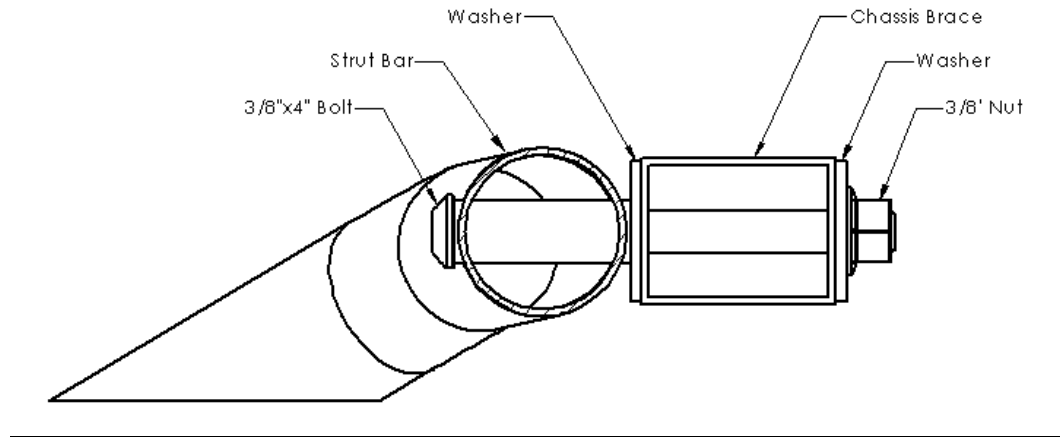

FIG F

For Technical Assistance Call: 1(888) 528-HEMI or 1(888) 528-4364.

NO PARTS WARRANTY – “AS IS”

Mopar Performance parts beginning with a “P” prefix are sold “as is” unless otherwise noted. This means that parts sold by Mopar Performance carry no warranty whatsoever. **Implied warranties, such as warranties of merchantability, are excluded.** (An implied warranty of merchantability means that the part is reasonably fit for the general purpose for which it was sold). The entire risk as to quality and performance of such parts is with the buyer. Should such parts prove defective following their purchase, the buyer and not the manufacturer, distributor or retailer, assumes the entire cost of all necessary servicing or repair. Chrysler, Dodge and Jeep® vehicle and parts warranties are voided if the vehicle or parts are used for competition. The addition of performance parts does not by itself void a vehicle’s warranty. However, added performance parts (parts not originally supplied on the vehicle from the factory) are not covered by the vehicle’s warranty, and any failure that they may cause is also not covered by the vehicle’s warranty.



INSTALLATION INSTRUCTIONS

2008-2011 DODGE CHALLENGER
2006-2011 DODGE CHARGER
2005-2011 CHRYSLER 300C
PART NUMBER P5155951AB

Strut Bar Kit Bill of Materials

A	1	Instruction Sheet
B	1	Strut Bar
C	1	Spacer
D	1	M12 Nut
E	2	M10 Washer
F	2	M14 Washer
G	2	M10 Lock-Nut
H	4	Closing Panel
I	6	Adhesive Back Velcro Strip
J	2	Templates

READ ALL INSTRUCTIONS BEFORE BEGINNING INSTALLATION

WARNINGS AND CAUTIONS:

MOPAR PERFORMANCE PARTS RECOMMENDS PROFESSIONAL INSTALLATION. A VEHICLE HOIST, TORQUE WRENCHES AND SPECIALIZED REMOVAL AND INSTALLATION TOOLS MAY BE REQUIRED.

STRUT BAR KIT INSTALLATION

Utilize a flat work area (preferably concrete).

1. Open the trunk and both (rear) doors. Fig A
2. Pull on the release handle to lower the rear seat-back and detach the seat-back cover from the spare tire cover. Fig B
3. Lift the spare tire cover up and out of the trunk. Fig C
4. Use the supplied template to mark the inner trunk panels for strut bar access cut-out.

Please refer to the supplemental instructions for detailed instructions. Fig D



INSTALLATION INSTRUCTIONS

2008-2011 DODGE CHALLENGER

2006-2011 DODGE CHARGER

2005-2011 CHRYSLER 300C

PART NUMBER P5155951AB

-
5. Use a suitable cutting tool to make the cut-out on the panel. Once the panel is cut, the inner insulation material will be visible. Fig E, F, G
 6. Use the cutting tool to cut away the insulation material to reveal the shock mount stud.
 7. Repeat step 4 to 6 for the other inner trunk panel utilizing the same template.
 8. From the rear seats, loosen and remove the M12 nut over the rear seat mount stud and place the supplied spacer over the adjacent stud. Fig H

For 2011 up Charger and Challenger, it is easier to install the strut bar with the horizontal brace removed.

9. Before the bar is installed, place one M14 washer over shock mount stud on each side and be sure it's seated perfectly flat on the shock mount. Install the bar's bracket over the stud and install M10 washer, M10 lock nut over the strut tower stud on each side. Slightly tighten but do not torque down at this time. Fig I, J, K & L
10. From the back seat, install the factory M12 nut on the rear seat mount and install the supplied M12 nut on the adjacent stud. Tighten but do not torque. Fig M & N
11. If the horizontal brace was removed, re-install the brace and tighten the bolts to 65 N-m (45 ft. lb.). Fig O & P
12. Tighten the rear seat mount M12 nuts to 115 N-m (85 ft. lb.) and the M10 shock mount stud lock nuts to 44 N-m (33 ft. lb.). Fig Q & R
13. Place the spare wheel cover on a flat work surface. Use the supplied template; mark the cover for the cut-out necessary to clear the strut bar. Use suitable cutting tool to cut out



INSTALLATION INSTRUCTIONS

2008-2011 DODGE CHALLENGER

2006-2011 DODGE CHARGER

2005-2011 CHRYSLER 300C

PART NUMBER P5155951AB

the marked area. Please refer to the supplemental instructions for detailed instructions.

Fig S to Fig V

14. Install the supplied closing panels over the cut-outs. Place the spare wheel cover back in the trunk and lift the rear seat-back. Fig W

15. RE-CHECK ALL YOUR WORK

Fig A



Fig C



Fig B



Fig D





INSTALLATION INSTRUCTIONS

2008-2011 DODGE CHALLENGER
2006-2011 DODGE CHARGER
2005-2011 CHRYSLER 300C
PART NUMBER P5155951AB

Fig E

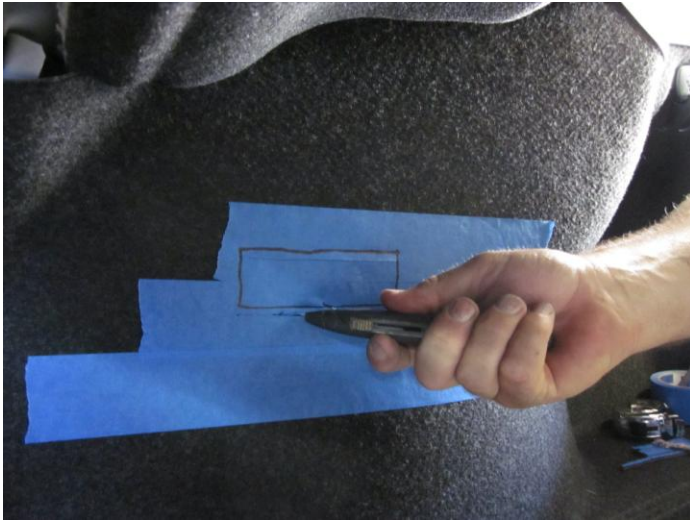

Fig F

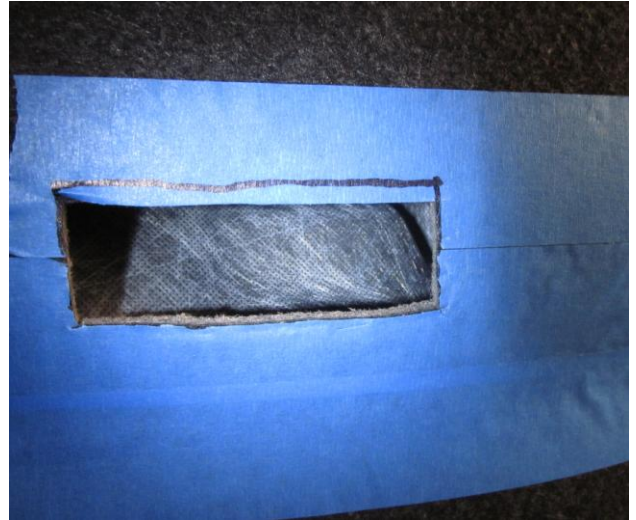

Fig G



Fig H





INSTALLATION INSTRUCTIONS

2008-2011 DODGE CHALLENGER
2006-2011 DODGE CHARGER
2005-2011 CHRYSLER 300C
PART NUMBER P5155951AB

Fig I



Fig J



Fig K



Fig L





INSTALLATION INSTRUCTIONS

2008-2011 DODGE CHALLENGER
2006-2011 DODGE CHARGER
2005-2011 CHRYSLER 300C
PART NUMBER P5155951AB

Fig M



Fig N



Fig O



Fig P





INSTALLATION INSTRUCTIONS

2008-2011 DODGE CHALLENGER
2006-2011 DODGE CHARGER
2005-2011 CHRYSLER 300C
PART NUMBER P5155951AB

Fig Q



Fig R



Fig S

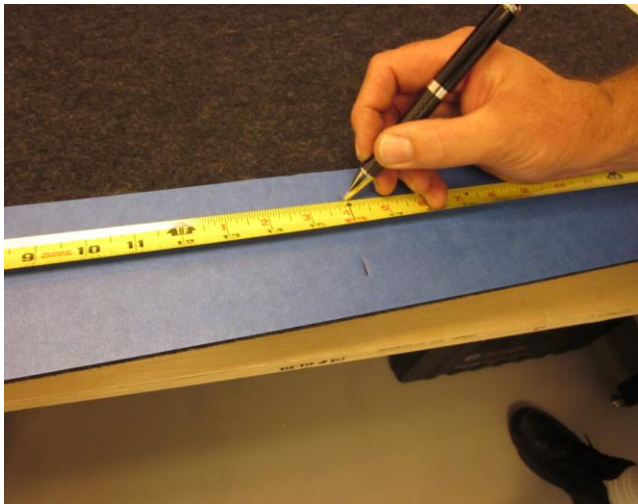
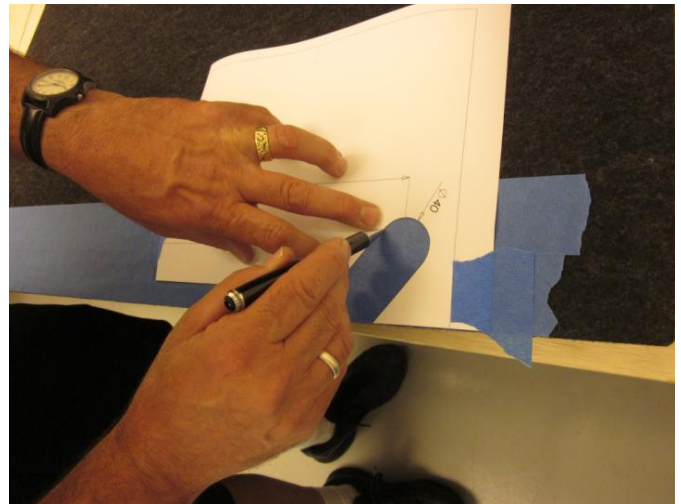

Fig T





INSTALLATION INSTRUCTIONS

2008-2011 DODGE CHALLENGER
2006-2011 DODGE CHARGER
2005-2011 CHRYSLER 300C
PART NUMBER P5155951AB

Fig U



Fig V

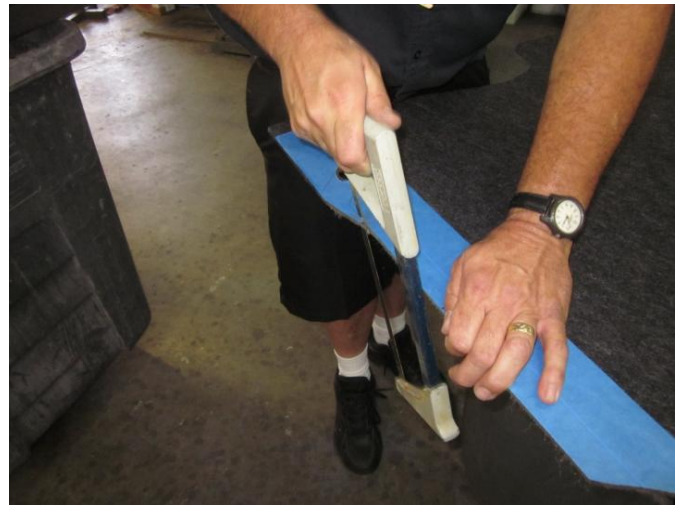

Fig W





INSTALLATION INSTRUCTIONS

2008-2011 DODGE CHALLENGER

2006-2011 DODGE CHARGER

2005-2011 CHRYSLER 300C

PART NUMBER P5155951AB



This is how the strut bar should look when properly installed

For Technical Assistance Call: 1(888) 528-HEMI or 1(888) 528-4364.

NO PARTS WARRANTY – “AS IS”

Mopar Performance parts beginning with a “P” prefix are sold **“as is”** unless otherwise noted. This means that parts sold by Mopar Performance carry no warranty whatsoever. **Implied warranties, such as warranties of merchantability, are excluded.** (An implied warranty of merchantability means that the part is reasonably fit for the general purpose for which it was sold). The entire risk as to quality and performance of such parts is with the buyer. Should such parts prove defective following their purchase, the buyer and not the manufacturer, distributor or retailer, assumes the entire cost of all necessary servicing or repair. Chrysler, Dodge and Jeep® vehicle and parts warranties are voided if the vehicle or parts are used for competition. The addition of performance parts does not by itself void a vehicle’s warranty. However, added performance parts (parts not originally supplied on the vehicle from the factory) are not covered by the vehicle’s warranty, and any failure that they may cause is also not covered by the vehicle’s warranty.



INSTALLATION INSTRUCTIONS

2008-2011 DODGE CHALLENGER
2006-2011 DODGE CHARGER
2005-2011 CHRYSLER 300C
PART NUMBER P5155951AB

Supplemental Instructions for the Carpet Trim template



a) The included Carpet Trim template is symmetrical so it is to be used for both left and right hand carpet trim panels. Two sets of templates are included. Use the appropriate template for your vehicle. Cut out the template with suitable cutting tool as outlined.

b) Transfer the outline of the template onto a piece of cardboard and cut it out with a suitable cutting tool. This will give rigidity to the template when laid over the panels.

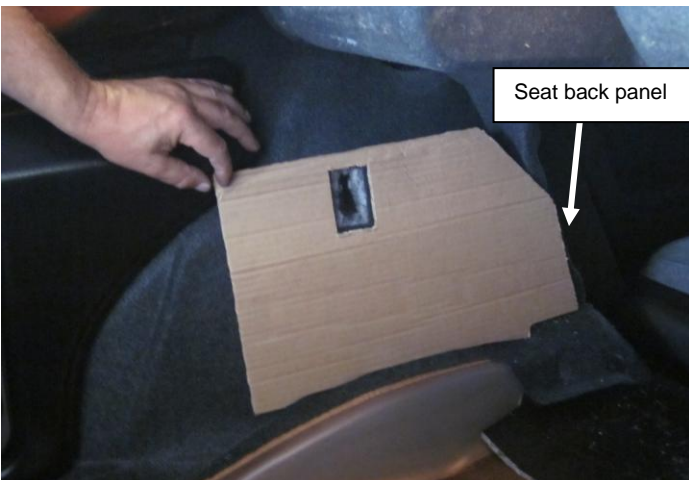

c) Start with the left hand side, lay the template over the left hand side panel and push it forward until it meets the seat back panel.

d) Use a suitable cutting tool, carefully cut out the area outlined in the template. Flip the template over and do the same to the right hand side panel.



INSTALLATION INSTRUCTIONS

2008-2011 DODGE CHALLENGER
2006-2011 DODGE CHARGER
2005-2011 CHRYSLER 300C
PART NUMBER P5155951AB

Supplemental Instructions for the Spare Wheel Cover trim template

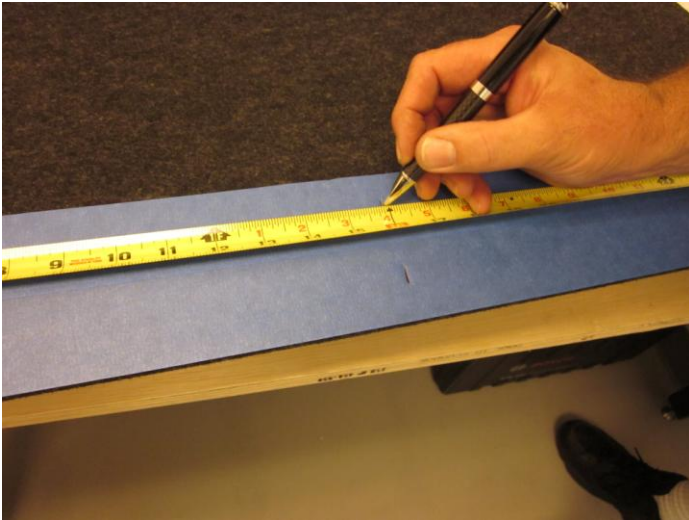

e) Rotate the spare wheel cover so you have the end of the cover that meets the seat back. Find and mark the center line. **Note: We recommend using masking tape for ease of marking and tracing.**

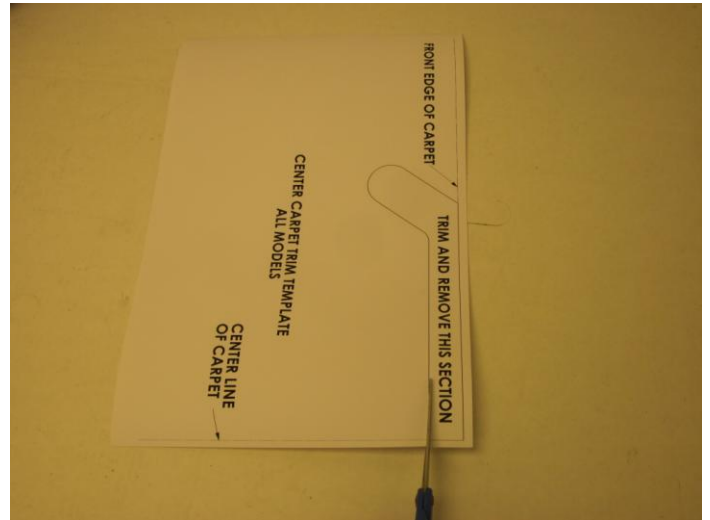

f) Cut out the template as outlined with suitable cutting tool. The template will be used front and back to mark the whole length of the spare wheel cover.

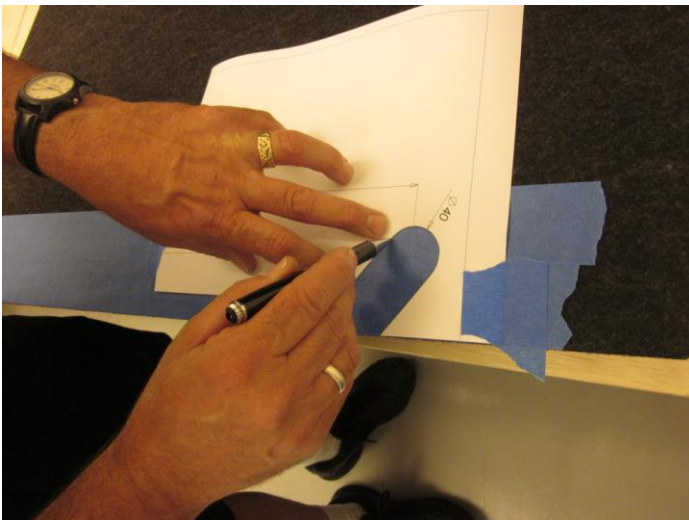

g) Place the template over the spare wheel cover to line up with the center line marked in step e.

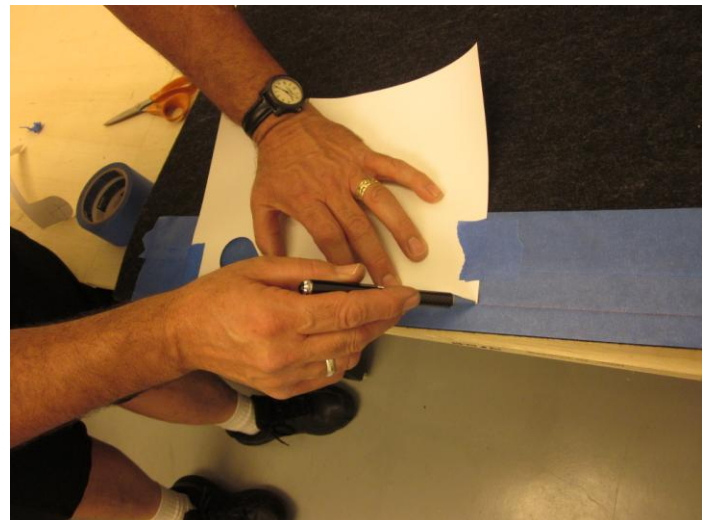

h) Trace the outline of the template onto the spare wheel cover one side at a time.



INSTALLATION INSTRUCTIONS

2008-2011 DODGE CHALLENGER
2006-2011 DODGE CHARGER
2005-2011 CHRYSLER 300C
PART NUMBER P5155951AB

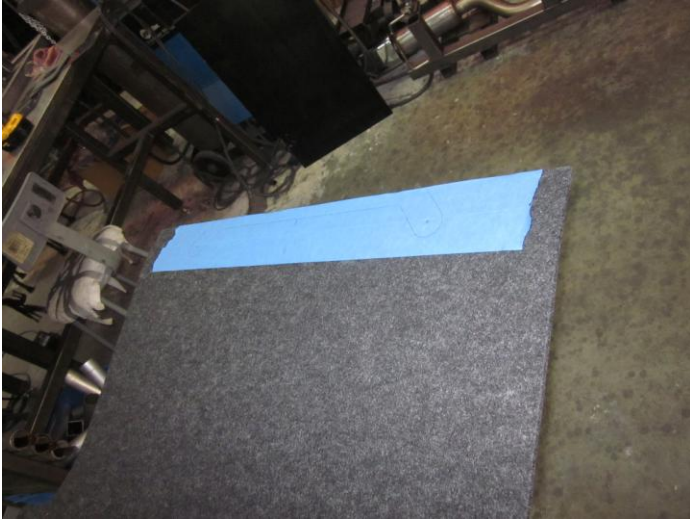

i) The template completely traced onto the spare wheel cover.



j) Use a hole-saw or jig saw to cut out the marked area.



k) Cutting of the spare tire cover in progress.



l) Hack saw or jig saw may be useful to perform final trimming.



INSTALLATION INSTRUCTIONS

2008-2011 DODGE CHALLENGER

2006-2011 DODGE CHARGER

2005-2011 CHRYSLER 300C

PART NUMBER P5155951AB

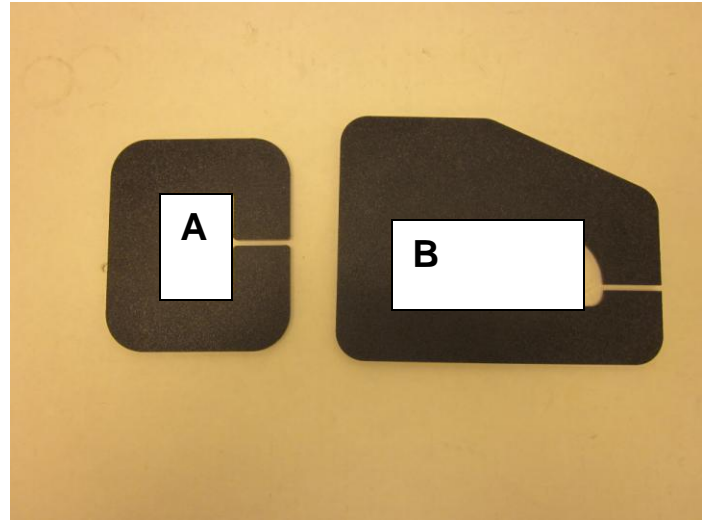
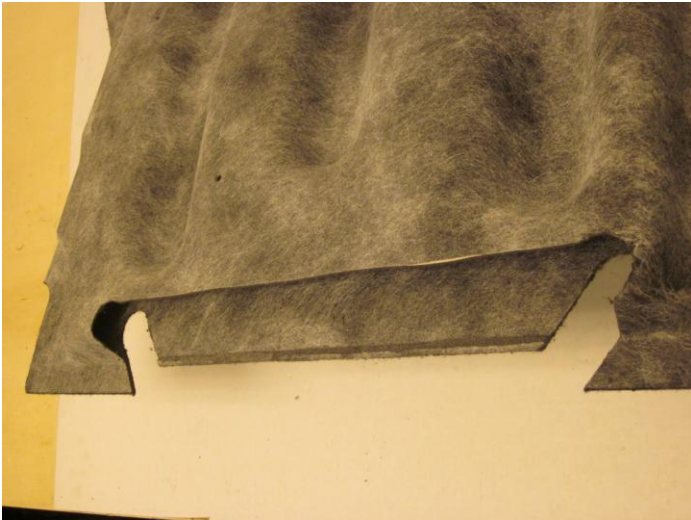

m) Due to different tolerances built into each car, it may be necessary to cut/trim underneath the spare wheel cover for needed clearance.

n) For 2008-2011 Dodge Challenger, 2006-2010 Dodge Charger, 2005-2010 300 use the close out panel A. For 2011 Charger and 2011 Dodge 300 use close out panel B.

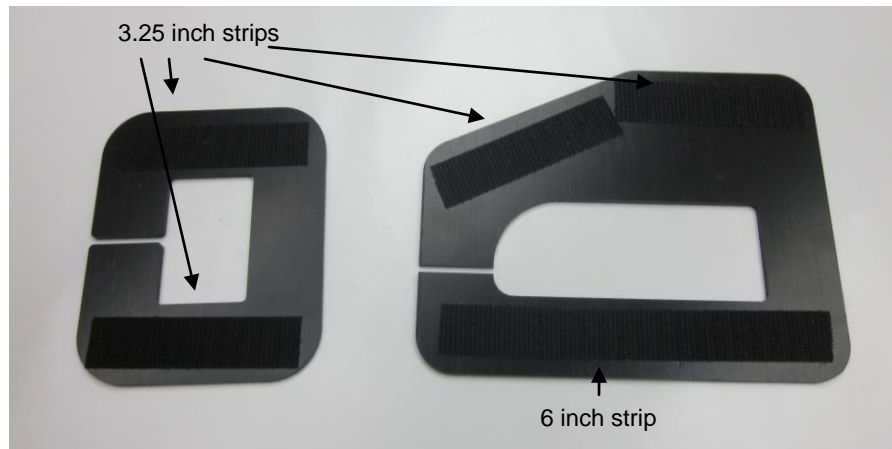

o) With correct close out panels selected for your vehicle model, apply the supplied adhesive backed Velcro as shown in the illustration before installation. **Note: Be sure the Velcro is applied to the smooth side as opposed to the textured side.**

FRONT EDGE OF CARPET

TRIM AND REMOVE THIS SECTION

(ϕ 1 5/8")

**CENTER CARPET TRIM TEMPLATE
ALL MODELS**

**CENTER LINE
OF CARPET**

**TRIM AND REMOVE
THIS SECTION**

**LEFT AND RIGHT HAND CARPET TRIM TEMPLATE
2011 DODGE CHARGER
2011 CHRYSLER 300**

SEAT BACK

FLOOR ARCH

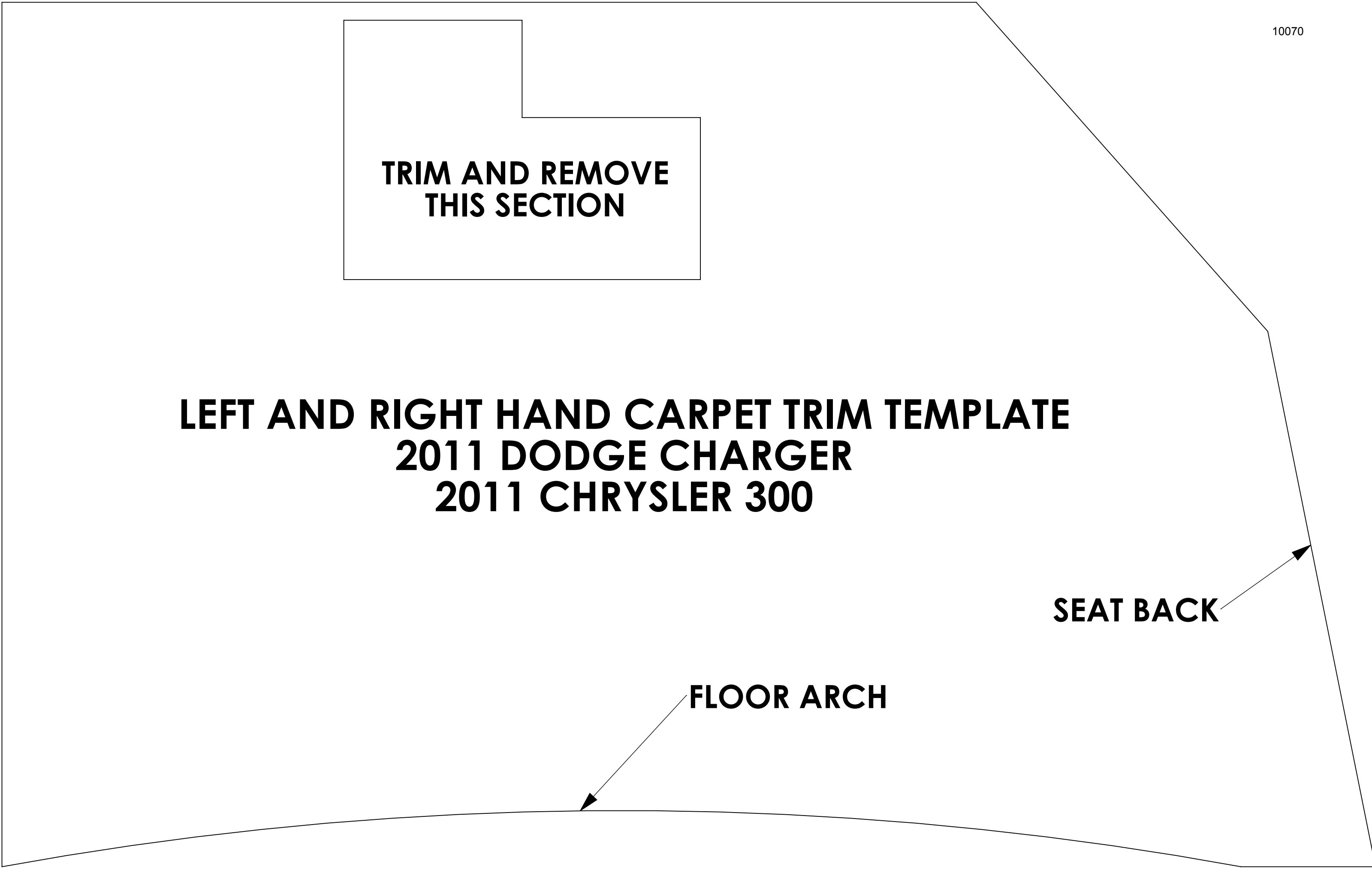

**TRIM
AND
REMOVE
THIS
SECTION**

**LEFT AND RIGHT HAND CARPET TRIM TEMPLATE
2006-2010 DODGE CHARGER
2005-2010 CHRYSLER 300
2008+ DODGE CHALLENGER**

SEAT BACK

FLOOR ARCH

